

# WEATHERPROOF DISCONNECT SPECIFICATIONS

YOU WILL NEED TO INSTALL THE FOLLOWING WEATHERPROOF PANEL PRIOR TO BREC CONNECTING YOUR ELECTRICAL EQUIPMENT.

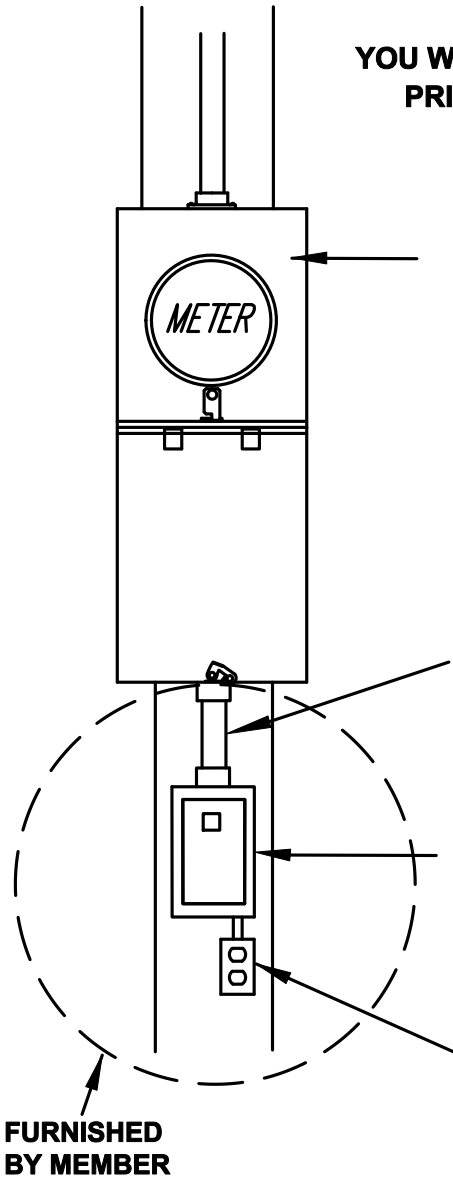

COMBINATION METER BASE AND MAIN DISCONNECT MOUNTED ON POLE.

ELECTRICAL CONDUIT (SIZED TO MATCH WIRE) FASTENED AT BOTH ENDS WITH LOCK RINGS AND SMOOTH BUSHINGS. A GROUNDING BUSHING IS RECOMMENDED ON METAL CONDUIT.

WEATHERPROOF PANEL - MINIMUM SIZE IS 30 AMP. INDIVIDUAL BREAKER(S) TO MATCH OUTGOING CIRCUITS. PANEL SHOULD BE FASTENED TO POLE.

WEATHERPROOF RECEPTACLE WITH COVERS - THE RECEPTACLE AMPERAGE RATING SHOULD MATCH THE WIRE SIZE AND BREAKER SIZE THAT IS SERVING IT. THE RECEPTACLE SHOULD BE CONNECTED TO THE PANEL WITH CONDUIT USING LOCK RINGS AND SMOOTH BUSHINGS.

NOTE: NUMBER OF WIRES IN CONDUIT WILL NOT EXCEED NEC LIMITS.

## WIRE SIZE CHART

PANEL RATING	WIRE SIZE	
	COPPER	ALUMINUM
30	10	--
40	8	--
60	6	4
100	4	2
125	2	1/0
150	1/0	2/0
200	2/0	4/0

## CONDUIT SIZE CHART

WIRE SIZE	12	10	8	6	4	1	1/0	2/0	4/0	250
CONDUIT SIZE	1/2"	1/2"	1/2"	3/4"	1"	1-1/4"	1-1/2"	1-1/2"	2"	2"

## WEATHERPROOF DISCONNECT SPECIFICATIONS

DRAWN: R.A.  
DATE: 9/4/15

CHECKED: D.B.  
DATE: 9/18/15

APPROVED: P.M.  
DATE: 9/30/15

REV 1



**BLACK RIVER ELECTRIC COOP**

2600 HIGHWAY 67  
FREDERICKTOWN, MO 63645

## REVISIONS

REV	DESCRIPTION	DATE	APPROVED
2	ADD 'FURNISHED BY MEMBER' NOTATION	8/26/24	DB